

NO	QTY	PART NO	DESCRIPTION	SEAL KIT
1	1	21510003	NUT, JAM, HEX, M14-1.50	
2	3	23350086	SPRING, COMPRESSION	X
3	3	23650010	BALL, TUNGSTEN-CARBIDE, 6mm	X
4	4	39051080	O-RING, (10mm X 1)	X
5	1	39051084	O-RING, (50mm X 2)	X
6	2	39051088	O-RING, (8mm X 3)	X
7	1	39053045	SEAL, WIPER, SNAP IN, WED, 28, 94A, AU	X
8	1	39056005	SEAL, STEP, ROD, 28	X
9	1	39056024	SEAL, CAP, PISTON, 50, 90A, AU GRPHT FLD	X
10	2	43068006	PLUG, PORT, HOLLOW HEX, G1/4	
11	1	81400144	PLUNGER, SC, 7MPa, 50B, RH	
12	1	81400154	CAP, LC/SC, 7MPa, 50B	
13	4	81400201	PLUG, MANIFOLD, 7MPa, M10	
14	3	81400203	PIN, STOP, BALL, METRIC, 6mm BALL	X
N/A	N/A	L6014500	KIT, SEAL, SC, 7MPa, 50B	NOTED

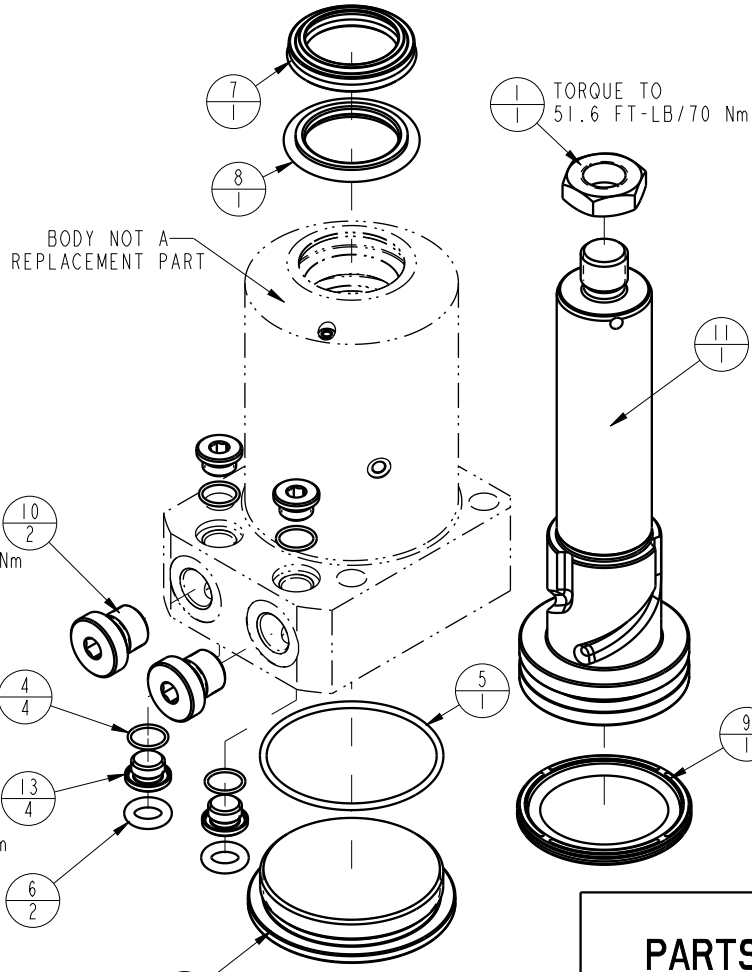

PARTS LIST		VEKTEK	
ASSEMBLIES AFFECTED		VEKTEK, INC. 1334 E. SIXTH AVE. P.O. BOX 625 EMPORIA, KS. 66801 U.S.A.	
L141500R		PARTS LIST, ASSY, SC, BF, 7MPa, 50B, RH	
SIZE A	LPL1419	REV B	

B	3273	RELEASE	JDW	08/15/18
REV	IN ACCORDANCE WITH ECN	EFFECTIVE DATE	REVISED BY	DATE
DRW BY: QMITCHELL	DRAWING STATUS: Released			
DATE: 7-17-13	PRODUCTION APPROVED FOR RELEASED STATUS ONLY			